

Elektrozugschiene Glydea

Modell P 595

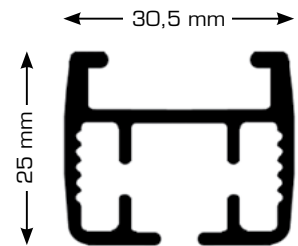

Abmessungen:

max. Schienenlänge: 12 m

Modellvarianten/ -merkmale :

- Montage wahlweise mit Schnellspannern (standard) oder Deckenclipsen (Montageabstand 50 cm)
- Laufgeschwindigkeit 15 cm/sek. (variabel einstellbar)
- Max. Behanggewicht lt. Belastungstabelle
- 10 Laufrollen je Meter Anlagenbreite

Profilfarben:

Standard:

- Aluminium eloxiert [E6/EV1] oder weiß [RAL 9016]

Alternativ:

- andere RAL-Töne auf Anfrage (Mehrpreis)

Zubehör:



Schnellspanner
(Standard)
Art. Nr. P - 8001



Deckenclip
Art. Nr. P - 8002



Roller mit Stahlachse und drehbarer Öse
Art. Nr. P - 8011



Metallhaken 40 mm
Art. Nr. P - 8012



Feststeller Metall
Art. Nr. F - 0264



Profilverbinder
Art. Nr. P - 8013



Wandträger 11 cm
Art. Nr. V - 1020 (weiß)
Art. Nr. V - 1021 (alu)



Wandträger 10 - 15 cm
verstellbar
Art. Nr. V - 1030 (weiß)
Art. Nr. V - 1031 (verzinkt)



Abdeckkappe Kunststoff
für verstellbaren Wandträger
Art. Nr. V - 1037 (weiß)
Art. Nr. V - 1038 (grau)

Wandträger 16 cm
Art. Nr. V - 1022 (weiß)
Art. Nr. V - 1023 (alu)

Wandträger 15 - 25 cm
verstellbar
Art. Nr. V - 1035 (weiß)
Art. Nr. V - 1036 (verzinkt)

Anschlussvarianten:

Bedienung über Standardschalter

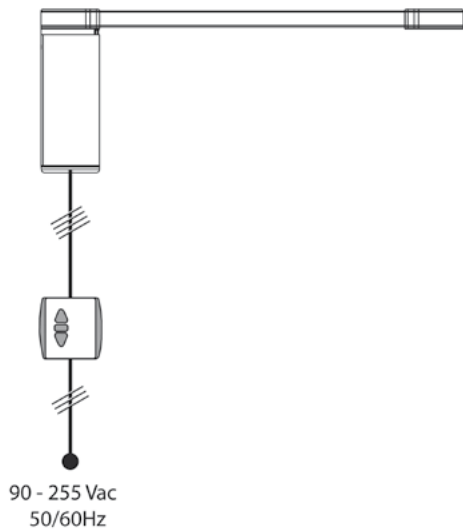

Inis uno inteo PF
Schalter
Art. Nr. 1325

Bei dieser Anschlussmöglichkeit sind nicht alle Produktfeatures möglich, da der Motor nicht unter Dauerspannung steht.

Bedienung über Funk (Mehrpreis)

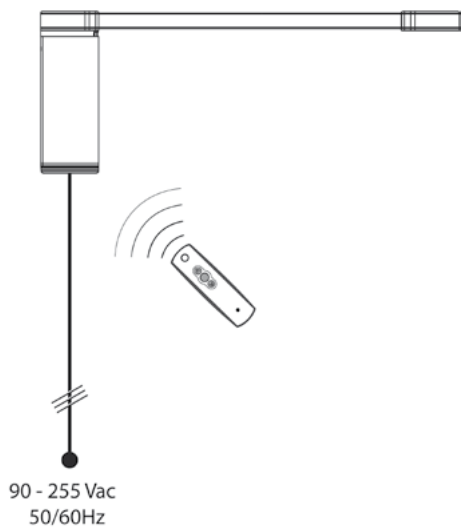

Funkempfänger
im Motorgehäuse
integrierbar
Art. Nr. 1316



Telis 1 RTS
1-Kanal-Funk-Hand-
sender
Art. Nr. 1315



Telis 4 RTS
4-Kanal-Funk-Hand-
sender
Art. Nr. 1310



Chronis RTS
Funk-Programm-
schaltuhr
Art. Nr. 1312



Chronis RTS L
Funk-Programm-
schaltuhr mit
Helligkeitsautomatik
Art. Nr. 1313

Bedienung über potentialfreie Kontakte

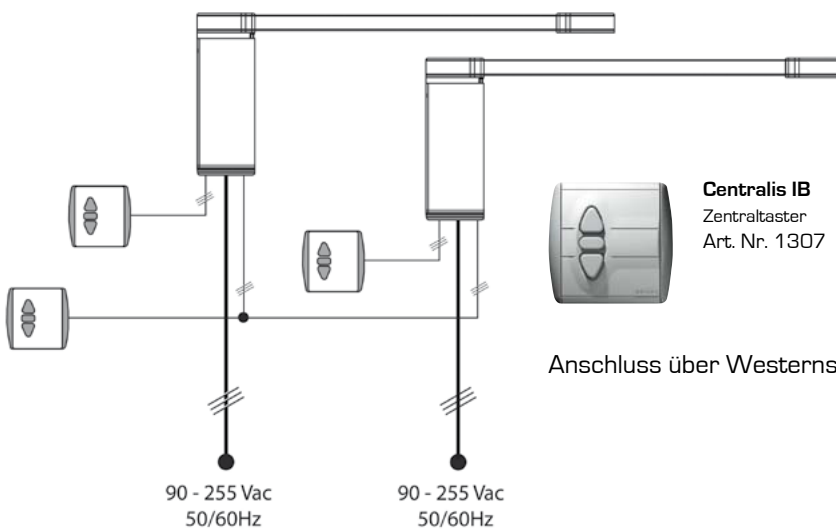



Centralis IB
Zentraltaster
Art. Nr. 1307

Anschluss über Westernstecker RJ 12 möglich.

Weitere Steuerungsmöglichkeiten und zusätzliche Geräte auf Anfrage.

Belastungstabelle:

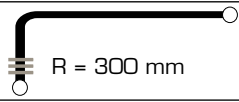
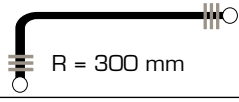
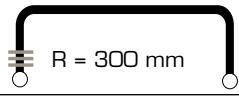
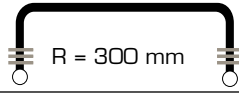
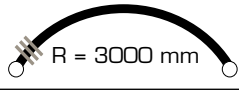
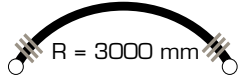
Spurtyp	6 m	10 m	12 m
	60 kg	60 kg	55 kg
	60 kg	60 kg	55 kg
	45 kg	45 kg	35 kg
	45 kg	45 kg	35 kg
	35 kg	25 kg	—
	35 kg	25 kg	—
	30 kg	8 m 30 kg	—
	30 kg	8 m 20 kg	—

Einbauprofil für Elektrozugschiene Glydea



Einbauprofil mit Elektrozugschiene Glydea

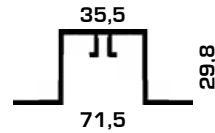

Einbauprofil
für Glydea 595

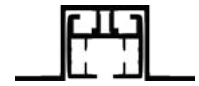

Einbauprofil mit
Elektrozugschiene Glydea



Einbauprofil mit Elektrozugschiene Glydea (kleine Umlenkung)

Einbauvarianten:

Einbau in
Decke



Einbau in
abgehängte Decke



Einbau in
abgehängte Decke
aus Metall



Draufsicht:

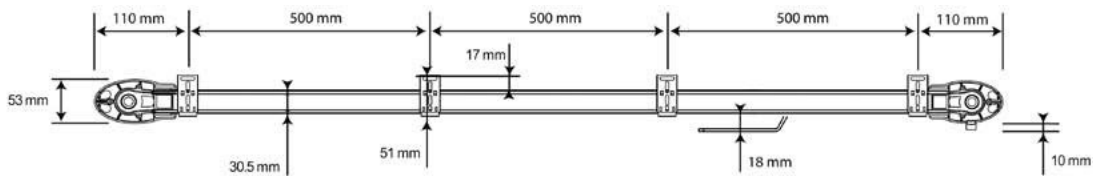

Seitenansicht:

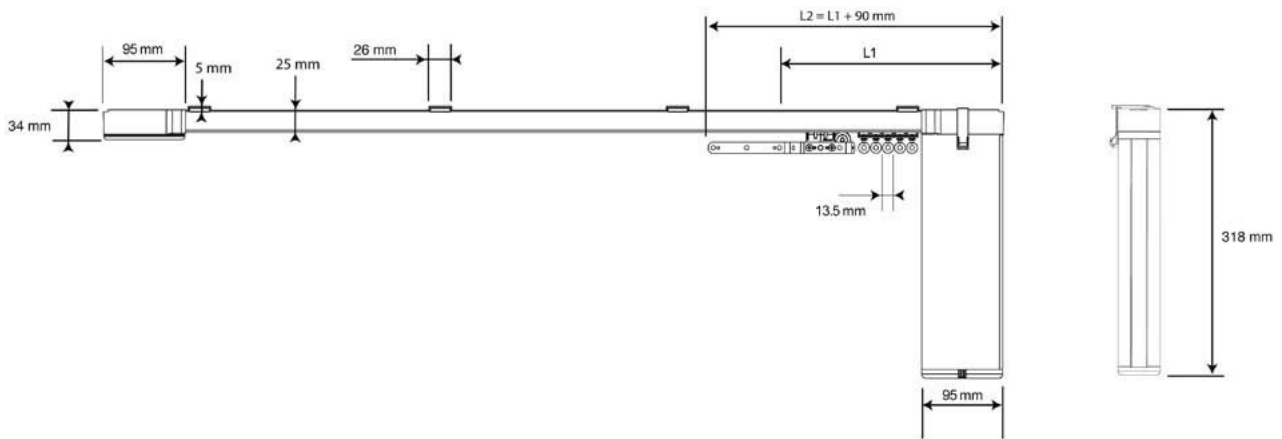

Montage:

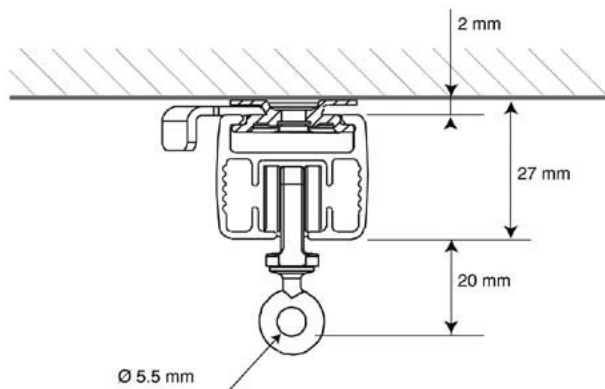

Montage mit
Schnellspanner (Standard)
Art. Nr. P -8001

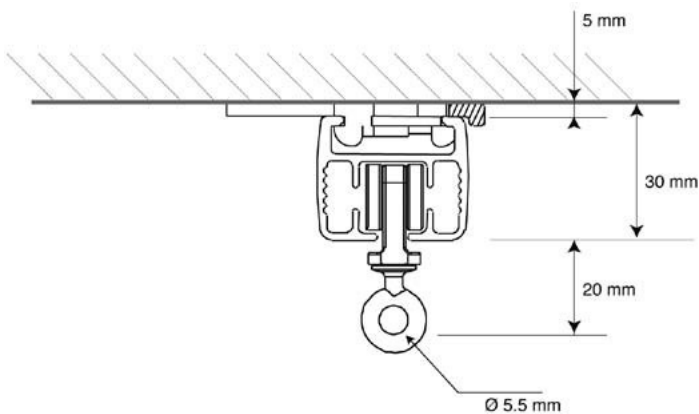

Montage mit
Deckenclip
Art. Nr. P -8002